

February 2010

Description

Featuring a very narrow installation footprint, miniMOORE™ Signal Isolators, Converters, Boosters and Splitters combine multiple analog signal channels in a rugged, easy-to-install signal conditioner.

Reliable and very economical, the miniMOORE multi-channel family includes the model MIX 2-wire (loop) and the model MIT 4-wire (line/mains) powered models. The complete family delivers cost-effective solutions for an expansive range of signal interface applications.

- **Isolate Signals** to stop erratic measurements caused by ground loops.
- **Convert Signals** from 0-5V, 1-5V or 0-10V to 4-20mA so field instruments can interface directly with an indicator, recorder, DCS, PLC or PC-based SCADA system.
- **Boost Signals** so more instruments can be added to an overburdened loop.
- **Split Signals** to allow one primary measurement to be sent to two, or up to four, separate systems.
- **Protect Equipment and Signals (Area Isolation)** by eliminating common electrical paths.
- **Solve “Bucking” Power Supplies** by stopping a conflict caused by a 4-wire transmitter and a DCS both trying to power the same process loop.

Choose from Model MIX 2-Wire (Loop-Powered) and Model MIT 4-Wire (Line/Mains-Powered):

| Model | Page |
|---|------|
| MIX 2-Wire, Output-Loop Powered • 2-Channel, Switch-Selectable Input/4-20mA Output • 4-Channel, Fixed 4-20mA Input/4-20mA Output | 2-5 |
| MIT 4-Wire, Line/Mains Powered • 2-Channel, Switch-Selectable Input/4-20mA Output | 6-7 |

 **UL** **us** Underwriter's Laboratories: General Location

 **CSAus** (US/Canada), Non-Incendive – Class I, Division 2, Groups A, B, C, D
Suitable for use in General Locations and Hazardous 'Classified' Locations when mounted in suitable protective enclosures.

 **CE** **Conformant** - EMC Directive 2004/108/EC EN61326;
Low Voltage Directive - 2006/95/EC EN61010



The miniMOORE's rugged metal construction delivers superior RFI/EMI protection and stands up to the daily rigors of demanding process and factory automation applications.

Features

- **High-density, 2- and 4-channel configurations.** At only 25.4mm (1 inch) wide, delivers up to four low cost I/O at 0.25 inch (6.35mm) per channel to substantially reduce panel space, installation and instrument costs.
- **Switch-selectable current/voltage inputs.** The 2-channel miniMOORE models provide DIP switches for selecting input types of 4-20mA, 0-5V, 1-5V or 0-10V for each channel.
- **2-wire (loop) and 4-wire (line/mains) powered.** Versatile choices allow you to match miniMOORE to the type of AC or DC power available at each location.
- **Superior signal isolation.** Industrial-strength input-to-output and channel-to-channel protection (up to 1000Vrms) stops ground loops, motor noise, and other electrical interferences from affecting process signals.
- **Universal AC/DC power input.** The 4-wire miniMOORE model automatically accepts any power input range between 20-125VDC and 90-250VAC.
- **RFI/EMI Protection.** miniMOORE provides an effective barrier against the unpredictable, harmful effects of radio frequency and electromagnetic interference.

MIX 2-Wire (Loop-Powered) Signal Isolators/Converters

The miniMOORE MIX 2- and 4-channel models draw their operating power from the loop output side where power is typically made available by the receiving device, such as a DCS or PLC.

The 4-channel MIX can take the place of four individual 4-20mA/4-20mA isolators (Figure 1). The 2-channel MIX provides conveniently-located DIP switches for selecting input types of 4-20mA, 0-5V, 1-5V or 0-10V for each channel (Figure 2).

Figure 1. The MIX 4-channel model saves panel space, installation and instrument costs by providing four independent input/output channels in a single instrument.

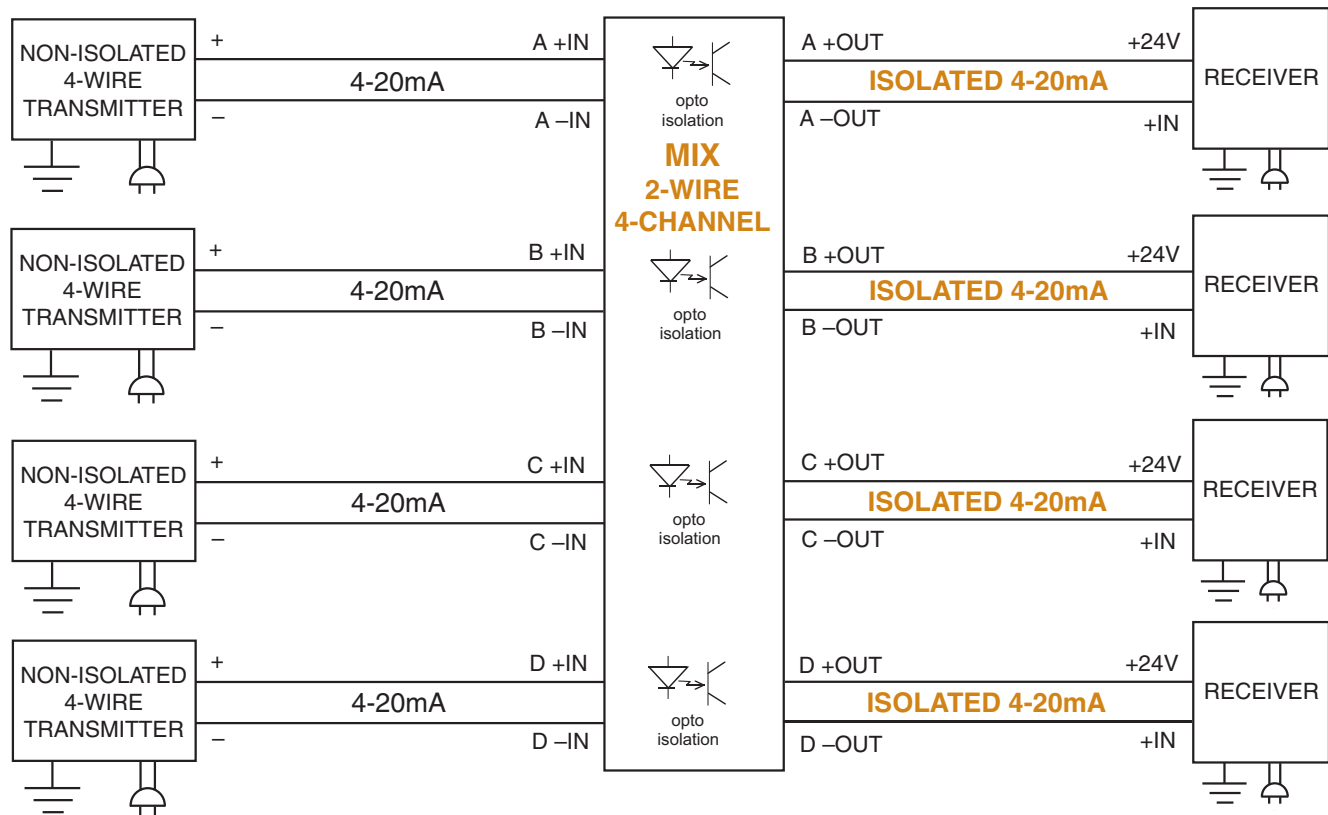
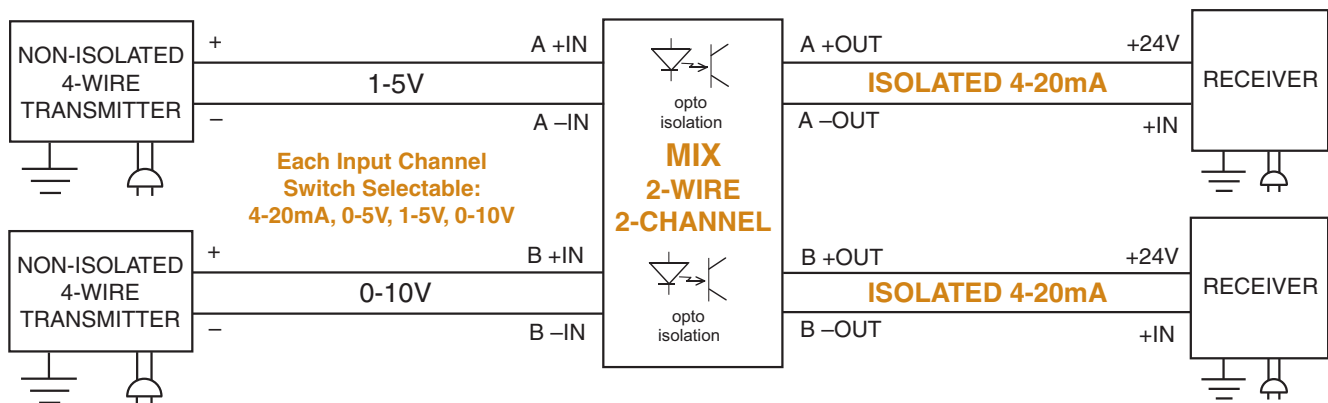

Figure 2. The MIX 2-channel model features switch-selectable input type for isolating and converting process signals.



**MIX & MIT Multi-Channel
Signal Isolators and Converters**

Stop Ground Loop Noise

Differences in potential between a grounded transmitter and a grounded receiving device may result in unpredictable ground loop problems, which can lead to signal drift. Use the miniMOORE model MIX to break the galvanic path between the field instrument and receiving device (Figure 3).

Convert Signals

The 2-wire, 2-channel MIX takes one or two separate process signal types (such as 1-5V and 0-10V) and converts them to standard isolated 4-20mA signals, allowing devices with incompatible signal types to interface with one another (Figure 2).

Divert and Protect (Area Isolation) Signals

Using a miniMOORE model MIX isolator you can send the output from one transmitter to a second location, protect expensive monitoring/control equipment by eliminating common electrical paths or create a buffer between devices to allow interruption of one leg of a loop without impacting the other (Figure 4).

Amplify (Boost) Signals

If you need to add an instrument to an overloaded loop, use the MIX. It features a high drive capability of 600 ohms (with a 24V power supply) and a low input impedance of just 50 ohms (Figure 5).

Solve “Bucking” Power Supplies

When two devices (such as a 4-wire transmitter and a DCS) are trying to source power to a loop, the result is a non-functioning loop. When neither device can be eliminated, the solution is the MIX. It can operate with powered inputs from both sides, thus restoring normal operations to the loop (Figure 6).

Figure 3. Input/output loop isolation.

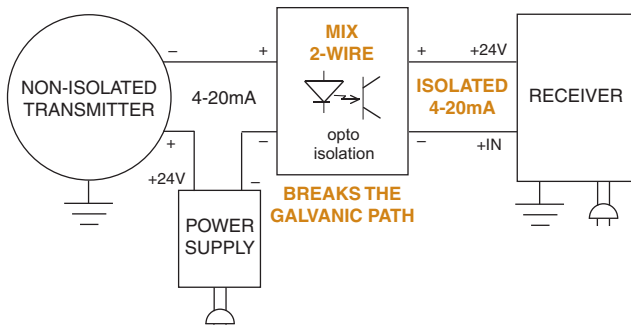

Figure 4. Divert a process signal, or protect expensive equipment by eliminating a common electrical path.

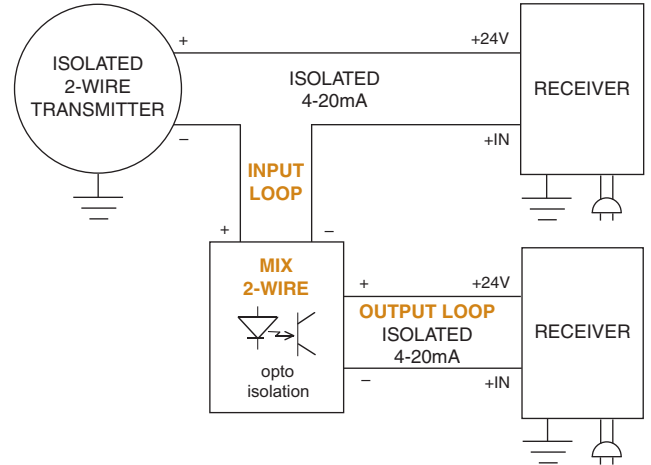

Figure 5. Boost a process signal to allow additional instruments to be added to a loop.

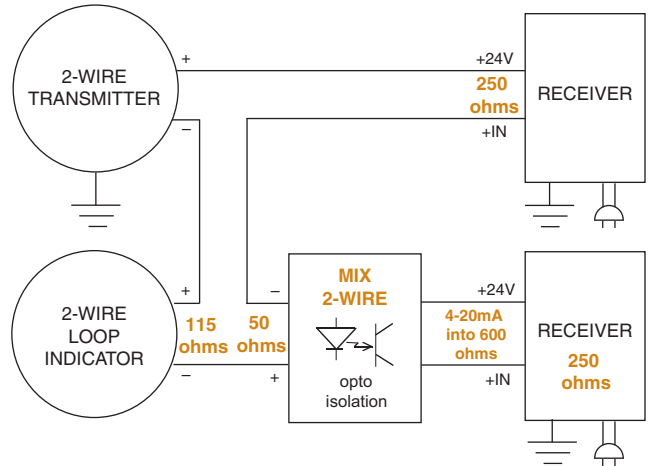
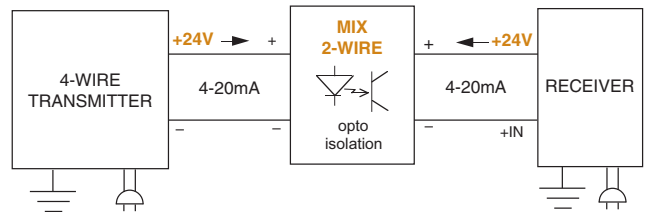

Figure 6. Restore a loop experiencing “bucking” power supplies to normal operation.



MIX & MIT Multi-Channel
 Signal Isolators and Converters

Share or Split a Process Signal

The model MIX miniMOORE is capable of accepting one input and splitting the signal to two separate signals (2-channel model) or up to 4 separate signals (4-channel model). This is valuable when multiple receivers must monitor one process signal, such as

in custody transfer, where two parties require identical information for accountability or billing purposes (Figure 7). Maintenance of one loop does not disrupt the integrity of the other.

Figure 7. The MIX 4-channel model can be used to split one 4-20mA signal into up to four proportional 4-20mA signals.

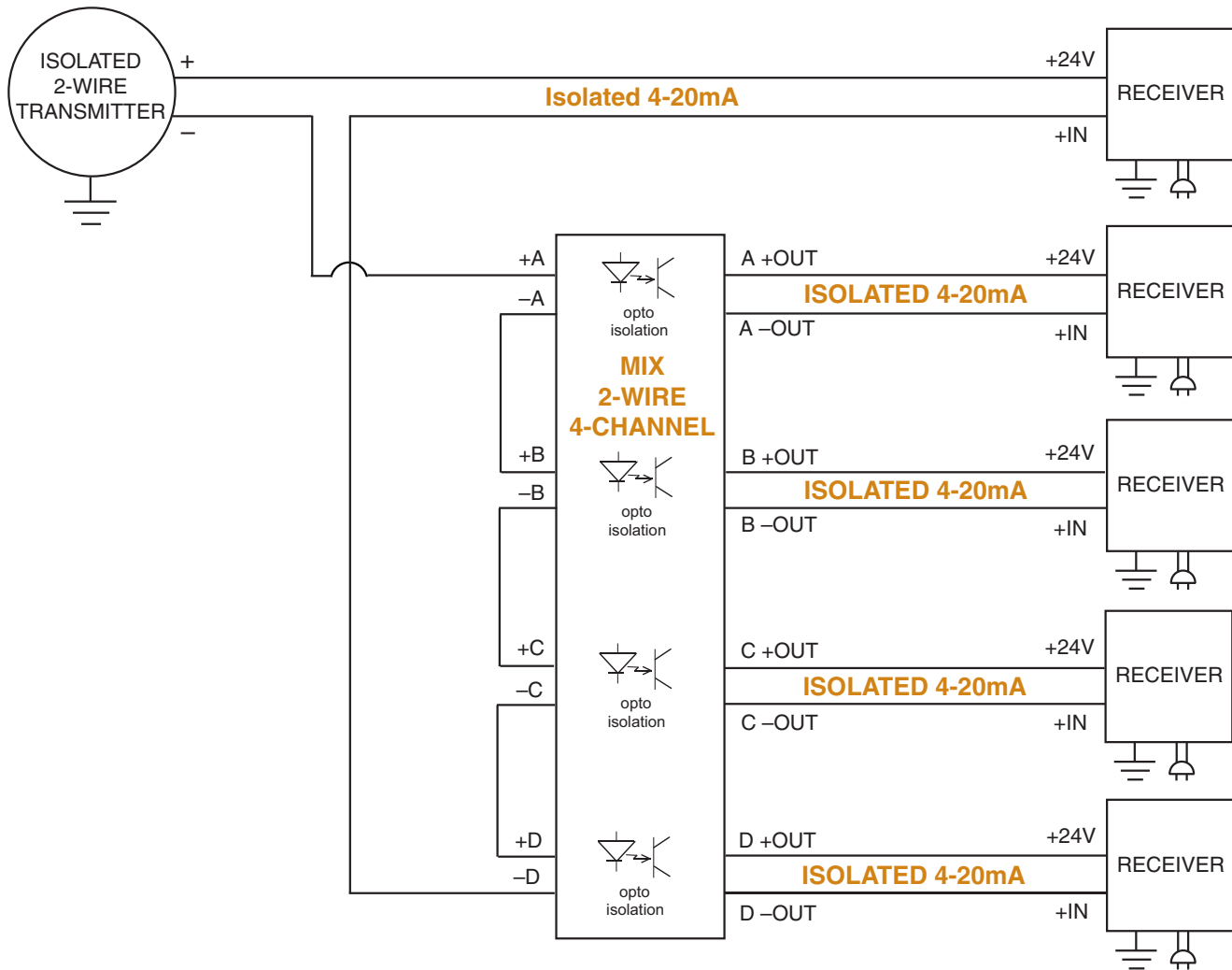

Specifications (MIX 2-Wire, 2- and 4-Channel)

| | | |
|--|--|---|
| <p>Performance Accuracy: ±0.1% of span (includes input accuracy, output accuracy, and the combined effects of linearity, hysteresis and repeatability) Stability: ±0.2% of reading per year Isolation: 1000Vrms between inputs and outputs and channel to channel Output Response Time: 100msec maximum to 99% of output change; 50msec to 90% output change DC Input Resistance: 50 ohms for current; 1 Mohm for voltage Ripple: <10mV peak-to-peak maximum measured across a 250 ohm resistor Over-Voltage Protection: 42V maximum on output; 42V reverse polarity protection on output</p> | <p>Performance (continued) Maximum Input Over Range: Current inputs, 100mA Voltage inputs, 150% of full scale Load Capability: $\frac{V_s - 12V_{dc}}{0.02A} = \text{ohms}$ Output Current Limiting: 25mA typical; 30mA maximum Ambient Conditions Operating Range: -40°C to +70°C (-40°F to +185°F) @ 12V-30V; -40°C to +55°C (-40°F to +131°F) @ 12V-42V Storage Range: -40°C to +85°C (-40°F to +185°F)</p> | <p>Ambient Conditions (continued) Ambient Temperature Effect: ±0.007% of span/°C typical; ±0.015% of span/°C maximum Relative Humidity: 0-95% non-condensing RFI/EMI Protection: 80%AM at 1KHz, 10V/m@20-1000MHz per IEC 61000-4-3 Common Mode Rejection: Exceeds 95dB@60Hz with a limit of 500Vrms Adjustments Type: Front panel potentiometers Span: ±10% Zero: ±5% (non-interactive when span is set first) Weight MIX 2-Channel, 230 g (8.1 oz) MIX 4-Channel, 241 g (8.5 oz)</p> |
|--|--|---|

Ordering Information

| Unit | Input | Output | Power | Options | Housing |
|---|--|---|----------------|-------------|--|
| MIX miniMOORE 2-Wire (Output Loop-Powered) Isolator and Converter | 2XPRG 2-channels, individually DIP switch selectable input range of 4-20mA, 0-5V, 1-5V or 0-10V | 2X4-20mA Two 4-20mA output channels | 12-42DC | None | DIN Universal DIN-style housing mounts on 32mm G-type (EN50035) and 35mm Top Hat (EN50022) rails |
| | 4X4-20mA 4-channels, fixed for 4-20mA | 4X4-20mA Four 4-20mA output channels | | | |

When Ordering Specify: Unit / Input / Output / Power / Housing
Model Number Example: MIX / 2XPRG / 2X4-20mA / 12-42DC [DIN]
MIX / 4X4-20MA / 4X4-20MA / 12-42DC [DIN]

MIT 4-Wire (Line/Mains-Powered) Signal Isolators/Converters

The miniMOORE MIT 2-channel model features a **universal line/mains power supply**, allowing it to be powered from any 20-125VDC or 90-250VAC source. The power input wire terminal is a different color (orange) that the input/output terminals (gray) to reduce wiring errors.

Stop Ground Loop Noise

Differences in potential between a grounded transmitter and a grounded receiving device may result in unpredictable ground loop problems, which can lead to signal drift. Use the MIT to break the galvanic path between the field instrument and receiving device (Figure 8).

Convert Signals

The 4-Wire, 2-Channel MIT takes one or two separate process signal types (such as 1-5V and 0-10V) and converts them to standard isolated 4-20mA signals, allowing devices with incompatible signal types to interface with one another (Figure 9).

Share or Split a Process Signal

The MIT is capable of accepting one input and splitting the signal to two separate signals. This is valuable when multiple receivers must monitor one process signal, such as in custody transfer, where two parties require identical information for accountability or billing purposes (Figure 10). Maintenance of one loop does not disrupt the integrity of the other.

Figure 8. Input/output loop isolation.

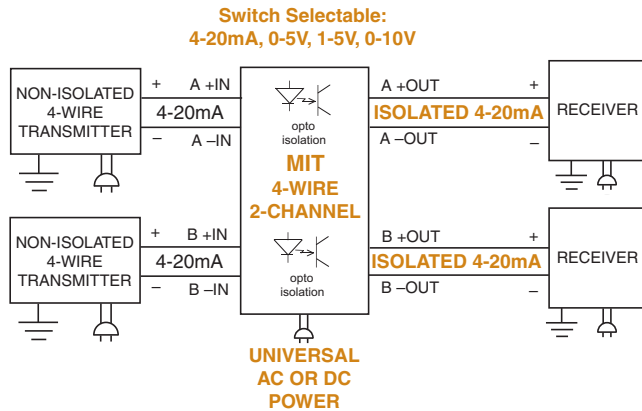

Figure 9. Input/output loop isolation and signal conversion.

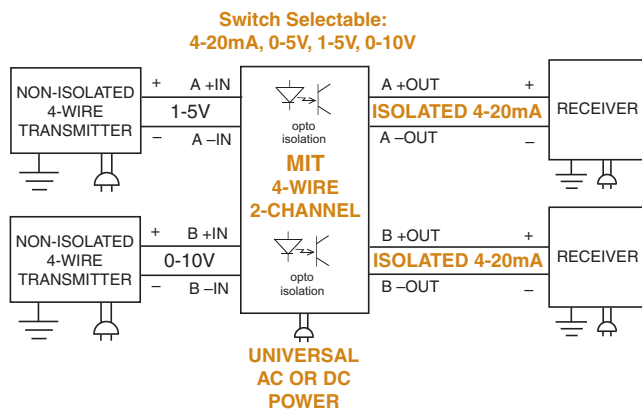
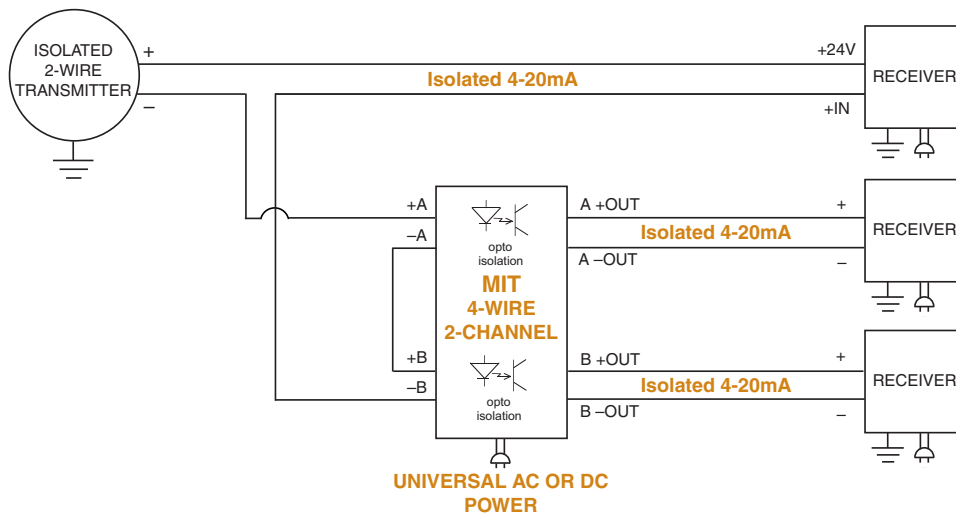

Figure 10. The MIT 2-channel isolator and converter can be used to split one 4-20mA signal into up to two proportional 4-20mA signals.



Specifications (MIT 4-Wire, 2-Channel)

| | | |
|--|--|---|
| <p>Performance Accuracy: ±0.1% of span (includes input accuracy, output accuracy, and the combined effects of linearity, hysteresis and repeatability) Stability: ±0.2% of reading per year Isolation: 1000Vrms between inputs and outputs and channel to channel; 2500Vrms between power supply and input, and power supply and output Output Response Time: 100msec maximum to 99% of output; 50 msec to 90% output change DC Input Resistance: 50 ohms for current; 1 Mohm for voltage Ripple: <10mV peak-to-peak maximum measured across a 250 ohm resistor Over-Voltage Protection: 30V maximum on output; 30V reverse polarity protection on output</p> | <p>Performance Maximum Input Overrange: Current inputs, 100mA maximum Voltage inputs, 150% of full scale Burden: 1V maximum for current; 1Mohms minimum for voltage Load Capacity: 600ohms max. Output Current Limiting: 25mA typical; 30mA maximum Power Supply: Universal, 20-125VDC or 90-250VAC Power Consumption: AC, 2W, 4VA max.; DC, 2.6W, 24VDC</p> <p>Ambient Conditions Operating Range: -40°C to +70°C (-40°F to +158°F) Storage Range: -40°C to +85°C (-40°F to +185°F)</p> | <p>Ambient Conditions Ambient Temperature Effect: (continued) ±0.007% of span/°C typical; ±0.015% of span/°C maximum Relative Humidity: 0-95% non-condensing RFI/EMI Protection: 80%AM at 1KHz, 10V/m@20-1000MHz per IEC61000-4-3 Common Mode Rejection: Exceeds 95dB@60Hz with a limit of 500Vrms</p> <p>Adjustments Type: Front panel potentiometers Span: ±10% Zero: ±5% (non-interactive when span is set first)</p> <p>Weight 263 g (9.3 oz)</p> |
|--|--|---|

Ordering Information

| Unit | Input | Output | Power | Options | Housing |
|--|---|---|---|-------------|--|
| MIT miniMOORE 4-Wire (Line/Mains-Powered) Isolator and Converter | 2XPRG 2-channels, individually DIP switch selectable input range of 4-20mA, 0-5V, 1-5V or 0-10V | 2X4-20mA Two 4-20mA output channels | U Universal, 4-wire (line/mains) power; accepts power input ranges of 20-125VDC or 90-250VAC | None | DIN Universal DIN-style housing mounts on 32mm G-type (EN50035) and 35mm Top Hat (EN50022) rails |

When Ordering Specify: Unit / Input / Output / Power / Housing
Model Number Example: MIT / 2XPRG / 2X4-20mA / U [DIN]

**MIX & MIT Multi-Channel
 Signal Isolators and Converters**

Figure 11. Installation dimensions for miniMOORE MIX 2-wire, 2- and 4-channel and MIT 4-wire, 2-channel models.

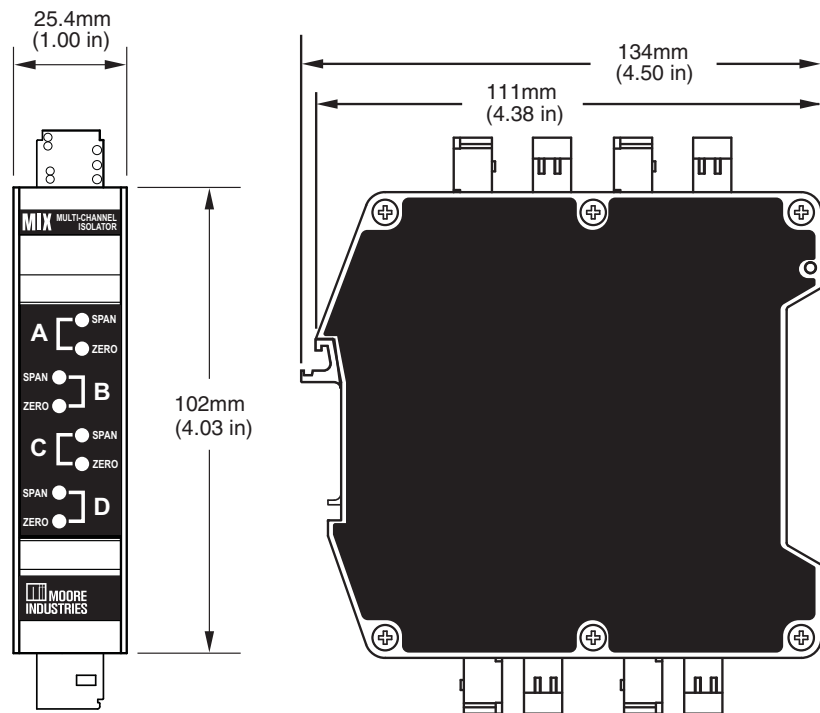

NOTES: MIX 2-Wire, 4-Channel Model Shown. All Models Share Identical Height and Width Dimensions.

On the MIT 4-Wire model, the power input wire terminal is a different color (orange) than the input/output terminals (gray) to reduce wiring errors.

Settings for Selectable Input Ranges

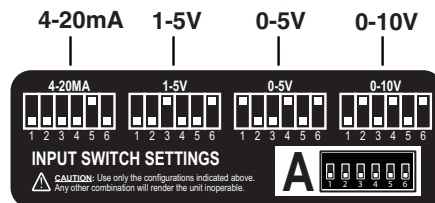

**MIX 2-Wire, 2-Channel and
 MIT 4-Wire, 2-Channel Models**

Need Enhanced Features?

PC-Programmable Universal Interface

Our model SIY Signal Isolator, Converter and Repeater is the ideal plant standard. This 2-wire (loop-powered), microprocessor-based instrument programs in less than a minute to handle a wide range of current and voltage inputs. It even allows creation of custom input linearization curves.

Unusual Input and Outputs

We have instruments that handle a wide array of non-standard inputs and outputs.

Custom Signal Isolators

We have engineers on hand to modify our instruments to meet your unique needs.

RTD, T/C, mV, Potentiometer, I/P, P/I, Strain Gage and Frequency Signals

We are the Interface Solution Experts. When you need to interface field processes with computer-based systems, readout equipment, and other instrumentation... our technology, services, and experience help you do it efficiently, safely and cost-effectively.